

# A Novel Shunt Active Filter Algorithms for a Three Phase System with Unbalanced and Distorted Source Voltage Wave Forms Feeding To Adjustable Speed Drive

<sup>1</sup>K.Sravanthi and <sup>2</sup>CH.Sujatha

Dept.of Electrical Engineering, Jntuk, Hyderabad (A.P)

<sup>1</sup>sravanthi.kusam@gmail.com <sup>2</sup>ksujathasagar@gmail.com

## ABSTRACT

*This paper presents the simulation of Shunt Active Power filter by using two different control schemes, indirect current control technique and ANN control technique. These two control techniques are working under both balanced and unbalanced three phase voltage source conditions and it is feeding to a adjustable speed drive the torque speed characteristics of a motor is presented. Indirect current control technique is implemented under dynamic load condition and load balanced condition. ANN control technique theory is used here to calculate the three phase line currents and voltages, the average power is determined and distributed proportionally among the three phases according to their instantaneous phase voltage. From this power we are calculating the compensating currents.*

**Index Terms--** Power Quality, Shunt active filter, indirect current control, ANN control

## 1. INTRODUCTION

The wide use of non-linear loads such as uninterrupted power supplies (UPS), adjustable speed drives (ASD), furnaces, and single phase computer power supplies etc cause power quality problems such as harmonic currents, poor power factor and voltage sag/swell increase in reactive power. There are several shunt active filtering algorithms developed. This paper presents the latest advanced techniques indirect current control and ANN Indirect control algorithm of the Active filter, the three-phase reference supply currents are obtained using a closed loop PI controller. A Hysteresis PWM current controller is employed over the reference and sensed supply currents to generate gating pulses of IGBT's of the Active filter. ANN based theory can work effectively under balanced as well as unbalanced source and load conditions because the compensating currents are calculated taking into account the magnitudes of per phase voltages. By using two control methods the THD values are compared and torque and speed variations for an adjustable speed drive with balanced and unbalanced voltage source are presented here. In this paper, simulation results of indirect current control technique and ANN control techniques are presented.

## 2. INDIRECT CURRENT CONTROL

The Figure 1 shows the basic control scheme of the AF using indirect current control. Three-phase voltages at PCC alongwith dc bus voltage of the AF are used for implementation of control scheme.

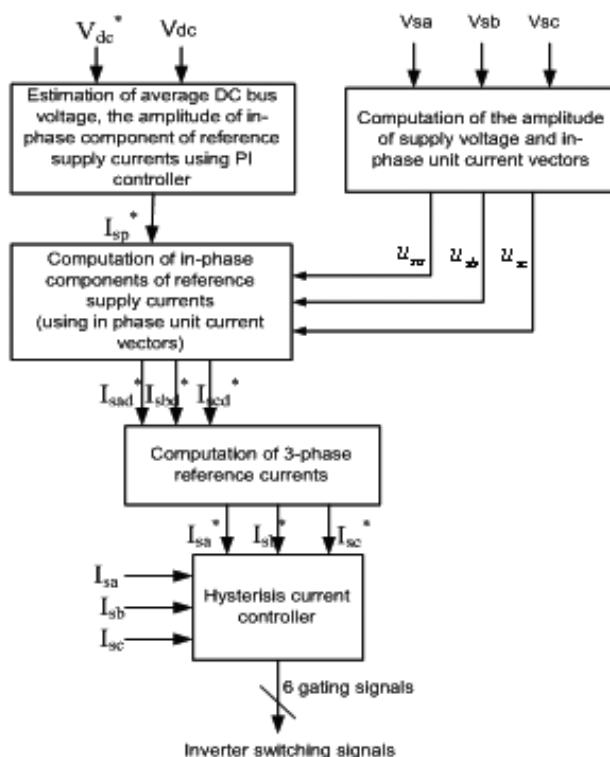
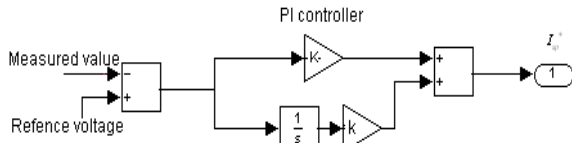

Figure 1 Control algorithm for indirect current control  
 Comparison of Average value of DC bus voltage ( $v_{dc}$ ) and

reference value of dc bus voltage ( $v_{dc}^*$ ) of the AF results in a voltage error, which is fed to a PI controller as shown in figure.

$$v_{derror} = v_{dc}^* - v_{dca}$$



Here, proportional ( $K_p$ ) and integral gains ( $K_i$ ) are so chosen, such that a suitable DC bus voltage response is achieved. The output of PI controller is taken as amplitude ( $I_{sp}^*$ ) of the reference supply currents.

Now, Three-phase in-phase components of the reference supply currents are computed using their amplitude and in-phase unit current vectors derived in-phase with the supply voltages, and are given by

$$i_{sa}^* = I_{sp}^* \cdot u_{sa}$$

$$i_{sb}^* = I_{sp}^* \cdot u_{sb}$$

$$i_{sc}^* = I_{sp}^* \cdot u_{sc}$$

Where  $u_{sa}$ ,  $u_{sb}$  and  $u_{sc}$  are in-phase unit current vectors and are derived as,

$$u_{sa} = v_{sa} / V_{sp}$$

$$u_{sb} = v_{sb} / V_{sp}$$

$$u_{sc} = v_{sc} / V_{sp}$$

Where  $V_{sp}$  is the amplitude of supply voltage and it is computed as

$$V_{sp} = \left\{ 2/3(v_{sa}^2 + v_{sb}^2 + v_{sc}^2) \right\}^{1/2}$$

Hence from the above procedure, the three phase reference supply currents are computed.

Now the three-phase reference supply currents and sensed supply currents are given as inputs to hysteresis current controller which generates gating signals for IGBT's of the AF.

**A. Implementation of hysteresis based current controller**

Hysteresis band PWM control is basically an instantaneous feedback current control method. The sine reference current wave is compared with the actual phase current wave. When the current exceeds a prescribed hysteresis band, the upper switch in the inverter bridge is turned off and the lower switch is turned on, and the current starts to decay. As the current crosses the lower band limit, the lower switch is turned off and the upper switch is turned on.

Hence the conditions for switching the devices are,  
 Upper switch on:  $(i^* - i) > HB$ .  
 Lower switch on:  $(i^* - i) < -HB$ .

The model of hysteresis controller, which is implemented in MATLAB for the current control purpose, is shown in below figure

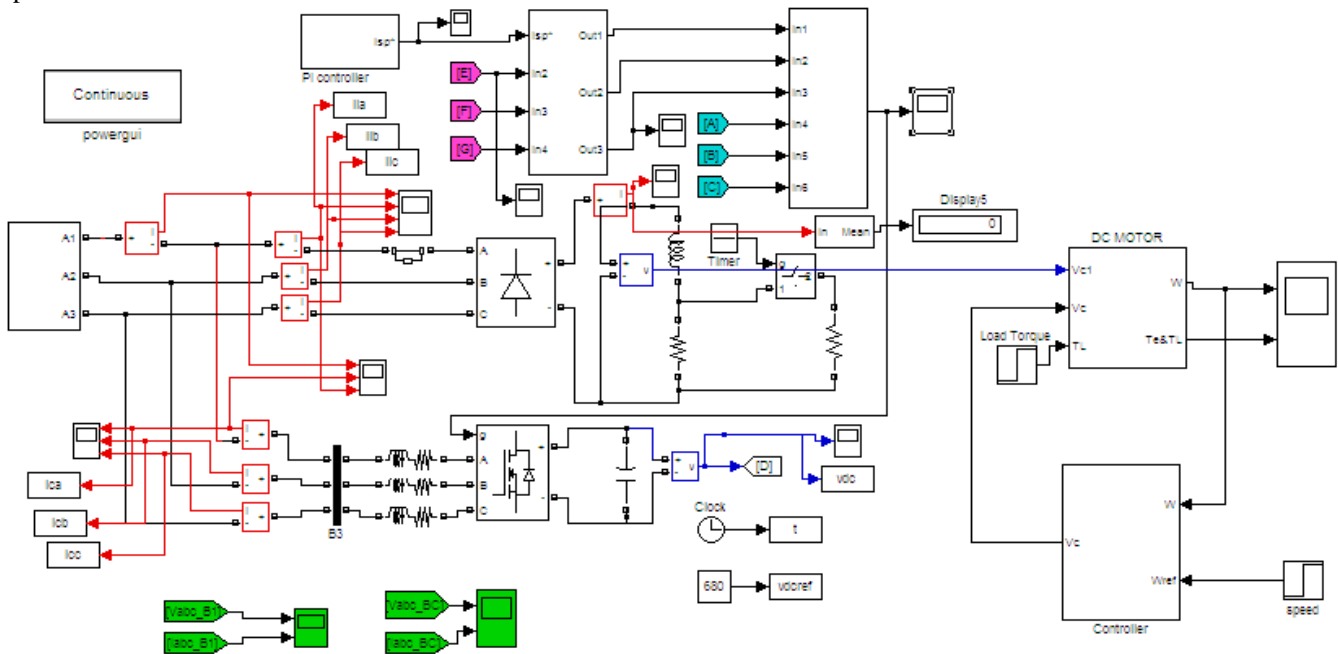
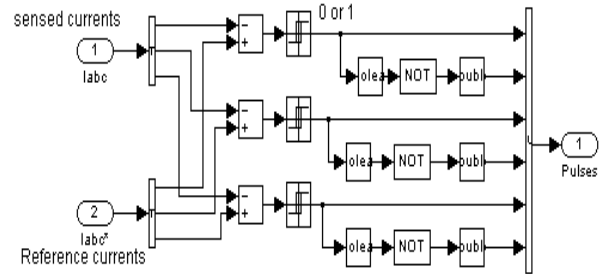

Figure 2 Simulation model for Indirect current control scheme in SIMULINK environment.

The simulation model for the indirect current control is shown in Figure 2. Three phase supply is used under both balanced and unbalanced conditions. Unbalanced case fifth and seventh harmonics are high. Third harmonic current was zero because of three phase. The input inductor, Dc bus capacitor used in AF is chosen as  $L_c = 3.35\text{mH}$ ,  $C_{dc} = 1500\mu\text{F}$ . The torque speed characteristics of adjustable speed drive is verified in both balanced and unbalanced condition.

### 3. ANN CONTROL TECHNIQUE

By using ANN block the three phase line currents and voltages monitored. Procedure for generating the ANN block is explained below.

**Training Data generation:** For the extraction of sequence currents the required inputs are three phase currents, and the corresponding outputs. The required inputs and outputs are generated in MATLAB program. In the program the input

Currents are initialized to zero, and incremented in steps. By taking one thousand samples in a cycle and arranging them in a vector of three rows, outputs also arranged in required vector size depends on the no of the outputs. The input vector size and output vector size must have same no of columns. The training data is generated for both balanced and unbalanced conditions. The number of the data required is depending on the network architecture and required error tolerance.

**Training the Network:** The training of the network was done with MATLAB program. The training data required the number of epochs, error and min\_gradient. The number of epochs depends on the error, and architecture of the network. First, the weights are initialized to random numbers. After training the first data the weights are adjusted to the required outputs. The training is done for both balanced and unbalanced conditions. After training, the network is simulated with trained inputs. If the network errors are within the predefined range then the architecture is suitable, otherwise the network architecture must be changed. After successful training the network can also give the required outputs with unknown inputs. After training the architecture is converted to simulink block.

By using ANN block monitoring the line currents and voltages, the average power is determined and distributed proportionally among the three phases according to their instantaneous phase voltage. From this power value, instantaneous current is calculated and subtracting it from the measured current, compensating component is determined.

Assume the peak values of source currents are balanced after compensation:

$$I_{am} = I_{bm} = I_{cm} = I_m$$

Peak values of active current in each phase after compensation are

$$I_{am} = \frac{2P_a}{V_{am}}, I_{bm} = \frac{2P_b}{V_{bm}}, I_{cm} = \frac{2P_c}{V_{cm}}$$

Where  $P_a$ ,  $P_b$  and  $P_c$  are real powers from each of the phases and  $V_{am}$ ,  $V_{bm}$  and  $V_{cm}$  are peak values of phase voltages in the three phases.

From the above equations

$$\frac{2P_a}{V_{am}} = \frac{2P_b}{V_{bm}} = \frac{2P_c}{V_{cm}}$$

Then

$$P_b = \frac{V_{bm}}{V_{am}} P_a$$

$$P_c = \frac{V_{cm}}{V_{am}} P_a$$

The total average power

$$P_{av} = P_a + P_b + P_c$$

By rearranging

$$P_a = \frac{V_{am}}{V_t} P_{av}$$

$$P_b = \frac{V_{bm}}{V_t} P_{av}$$

$$P_c = \frac{V_{cm}}{V_t} P_{av}$$

The reference active source currents are calculated as

$$i_{acc}(t) = \frac{2P_{av}}{V_{am} * V_t} v_{an}(t)$$

$$i_{bcc}(t) = \frac{2P_{av}}{V_{bm} * V_t} v_{bn}(t)$$

$$i_{ccc}(t) = \frac{2P_{av}}{V_{cm} * V_t} v_{cn}(t)$$

Where

$$V_t = V_{am} + V_{bm} + V_{cm}$$

The compensating current is obtained as

$$i_{can}(t) = i_{an}(t) - i_{acc}(t)$$

$$i_{cbn}(t) = i_{bn}(t) - i_{bcc}(t)$$

$$i_{cn}(t) = i_{cn}(t) - i_{ccc}(t)$$

The generation of training data and training the neural network is done in using the neural network toolbox commands. The neural network structure is converted into simulink diagram using the command *gensim*, to interface with the other power system blocks. The Figure3 shows the 3 layers of the neural network and the Figure4 shows the inside view of a layer. The Figure5 shows the no of the neurons of a layer. Simulation model for the ANN control technique is shown in Figure6.

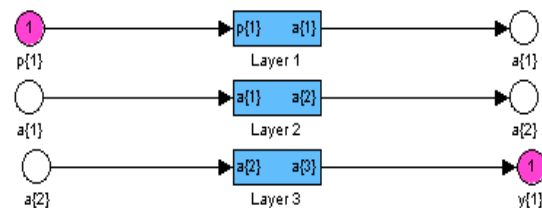

Figure 3 3Layer Feed-forward Neural Network

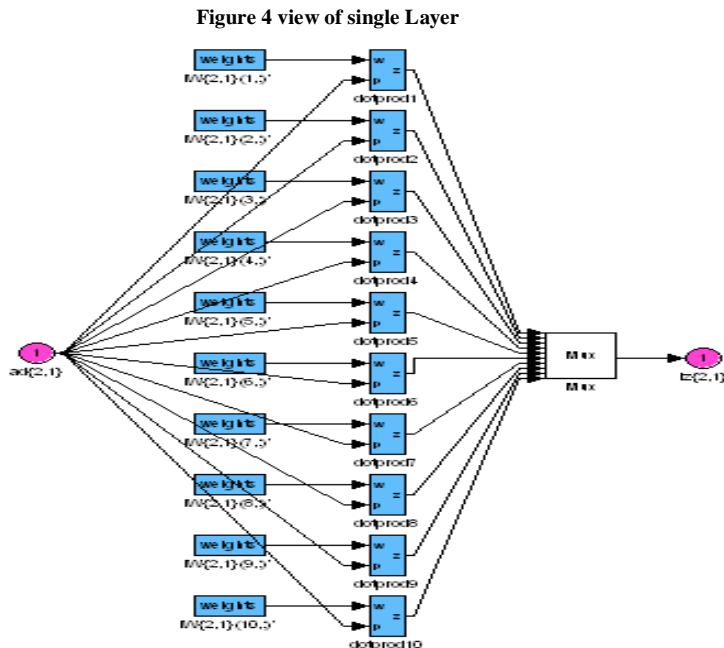
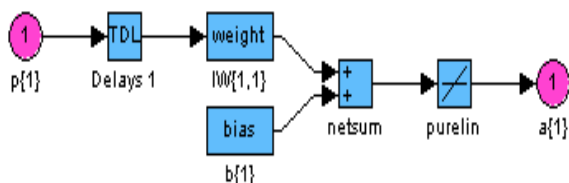

Figure 5 View of Weights of the layer one

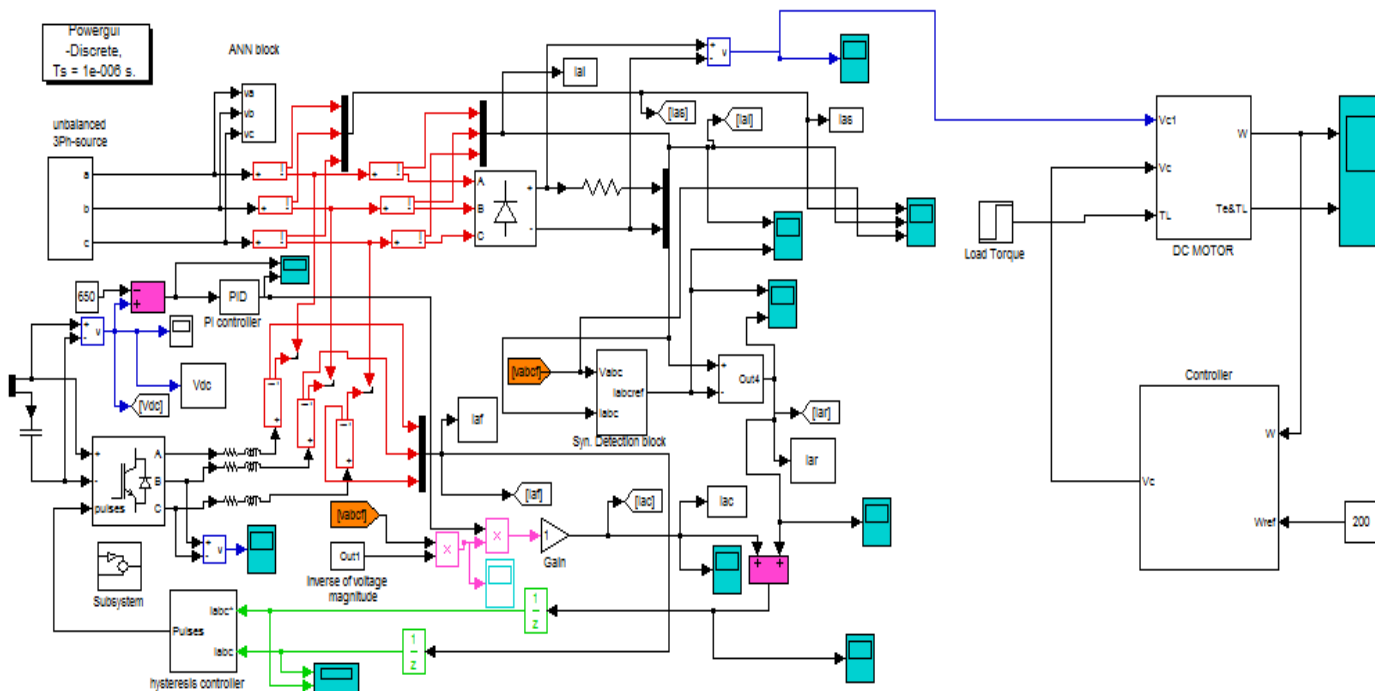

Figure6 Simulation Model for Shunt active Filter for proposed ANN method

#### 4. SIMULATION RESULTS

The simulation results of the shunt active power filter is carried in MATLAB/SimPowerSystems environment. The simulation results are shown below. As can be seen from the figure, the non-linear load is a three-phase bridge rectifier feeding an adjustable speed drive. The simulation is done for *Published: Singaporean Publishing*

various source and load conditions for providing harmonic compensation, load balancing and reactive power compensation. It can be clearly seen that by using ANN control technique THD value is less compared to indirect current control technique.

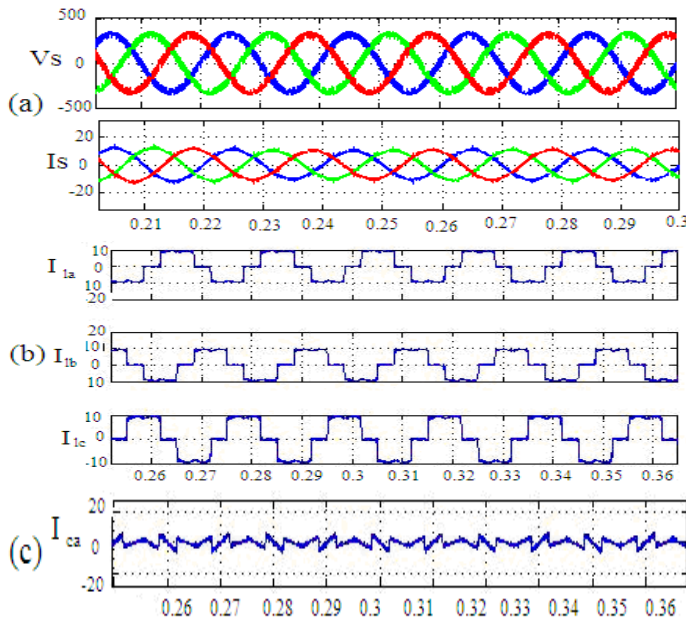

Figure 7 Indirect current control wave forms under balanced three phase (a) Supply voltage & current (b) load current (c) filter current

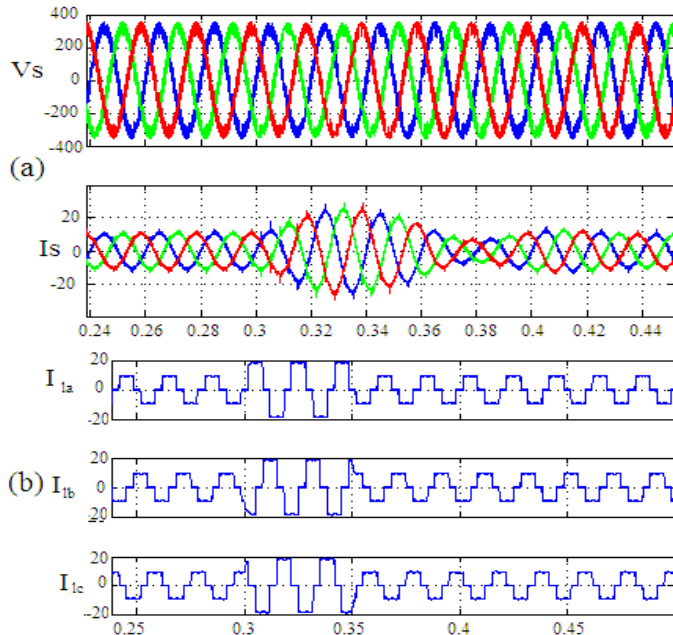

Figure 8 Indirect current control wave forms under dynamic load condition load is changing from 5KW to 10KW to 5KW. Three phase (a) supply voltage & current (b) Load current

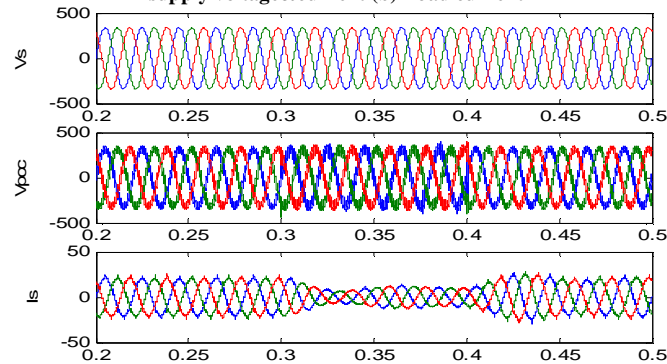

Figure 9 power factor is unity for supply voltage and current

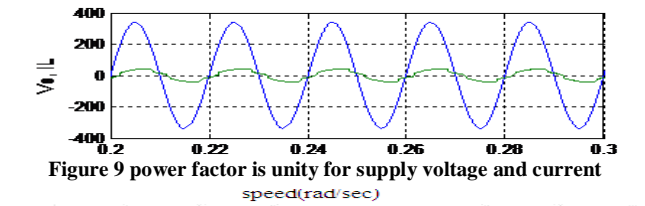

Figure 10 speed & torque wave forms of adjustable speed drive for Indirect current control

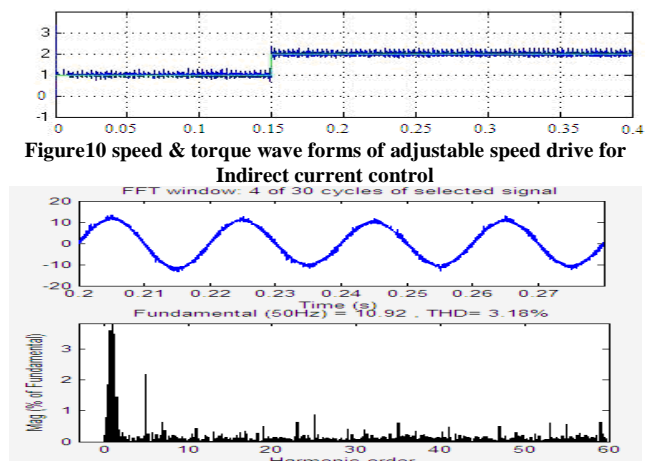

Figure 10 Indirect control FFT analysis for supply current

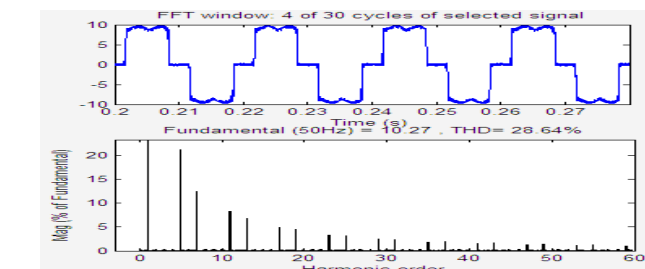
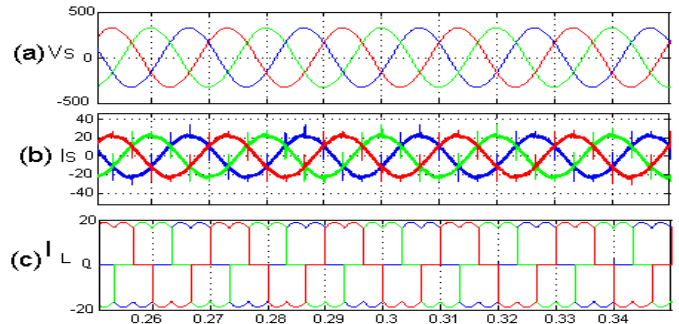

Figure 11 Indirect control FFT analysis for load current & filter current



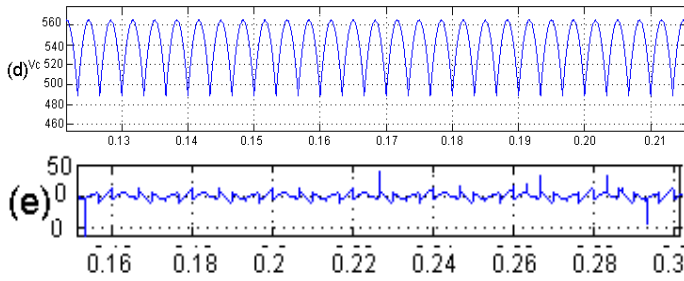

Figure 12 ANN control wave forms under balanced voltage. Three phase (a) supply voltage (b) supply current (c) Load current (d) output voltage (e) filter current

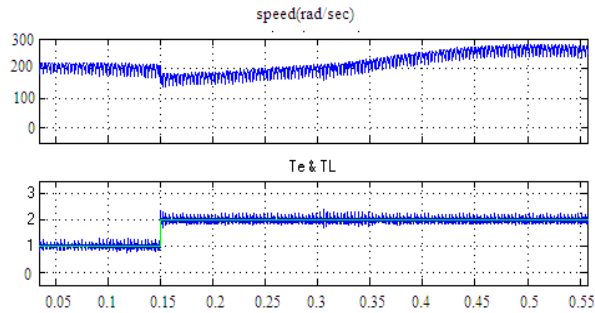

Figure 14 speed & torque wave forms of adjustable speed drive (ANN)

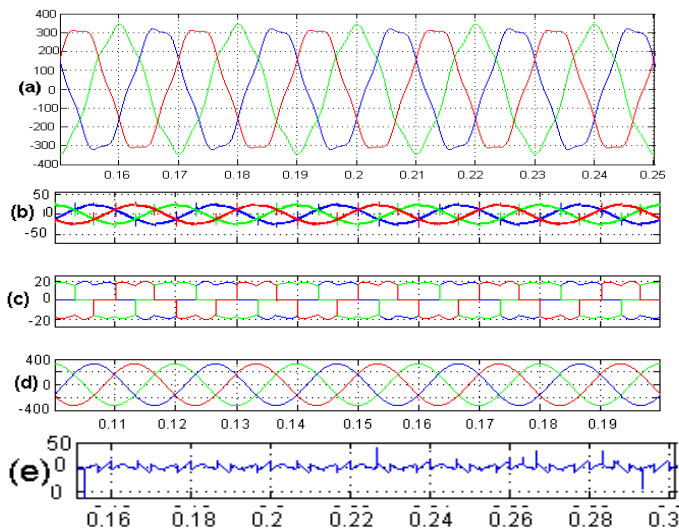

Figure 13 ANN control wave forms under unbalanced voltage. Three phase (a) supply voltage (b) supply current (c) Load current (d) supply voltage after balancing (e) filter current

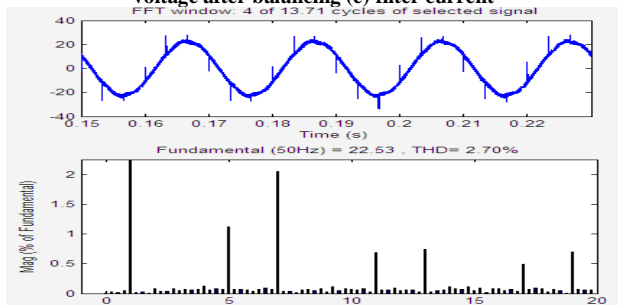

Figure 16 FFT analysis for supply current (ANN)

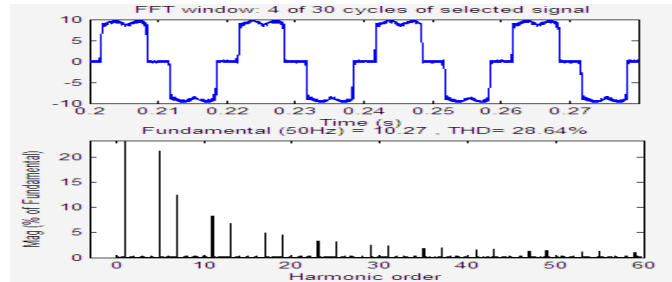

Figure 17 FFT analysis for load current, filter current (ANN)

Control techniques	THD
Indirect	3.18
ANN	2.70

Table: 1

Table 1 shows that by using indirect current control the THD value is high compared to ANN control technique. The harmonic content was eliminated in ANN control technique is high.

### 5. CONCLUSIONS

In this paper, indirect current control and ANN control methods using equalcurrent division technique has been applied to a shunt activepower filter to compensate for reactive and harmoniccurrents under balanced and unbalanced source voltageconditions. The simulation has been carried out inMATLAB/SIMULINK environment and power factor is unity for supply voltage, current.

### REFERENCES

- [1] C.K.Duffey and R.P.Stratford, "Update of Harmonic Standard IEEE-519 IEEE Recommended Practices and Requirements for Harmonic control in Electric Power System," *IEEE/IAS Transactions*, Nov. /Dec. 1989, pp.1025-1034.
- [2] Australian Standard (AS1359.31-1986), "Rotating Electrical machines –General Requirements," 1986.
- [3] *European Standard IEC- 34-1(1983)*, "Rotating Electrical machines," 1983.
- [4] Annette von Jouanne and Basudeb (Ben) Banerjee, "Assessment of Voltage Unbalance," *IEEE Transactions on power delivery*, Vol. 16, no. 4, Oct. 2001, pp. 782 – 780.
- [5] F.Z.Peng, D.J.Adams, "Harmonic sources and filtering approaches-series/parallel, active/passive, and their combined power filters," *Conference Record of the IEEE 34th IAS Annual Meeting*, Vol. 1, 3-7 Oct. 1999, pp. 448 – 455.
- [6] L.M.Tolbert, H.D.Hollis, and P.S Hale, "Survey of Harmonics Measurements in Electrical Distribution Systems," *Industry Applications conference, 1996. 31st IAS Annual Meeting*, Conference record of the 1996 IEEE.
- [7] IEEE Task Force, "Effects of harmonics on equipment," *IEEE Transactions on Power Delivery*, Vol. 8, Apr. 1993, pp. 672-680.
- [8] IEEE Task Force, "The effects of power system harmonics on power system equipment and loads," *IEEE Transactions on Power Apparatus and Systems*, vol. 104, Sept. 1985, pp. 2555-2563.

- [9] Hugh Rudnick, Juan Dixon and Luis Moran, "delivering clean and pure power," *power energy magazine, IEEE*, Vol. 1, No. 5, Sep-Oct 2003, pp. 32-40.
- [10] B. Singh, K.Al-Haddad, A. Chandra, "A review of active filters for power quality improvement," *IEEE Transactions on Industrial Electronics*, Vol. 46, No. 5, Oct.1999, pp.960 - 971
- [11] M. El-Habrouk, M.K.Darwish, P.Mehta, "Active power filters: a review,"*Electric Power Applications, IEE Proceedings*, Vol. 147, No. 5, Sept. 2000 pp. 403 – 413.
- [12] NormanMarium, AhsanulAlam, SenanMahmod and HashimHizam,"Review of control strategies for power quality conditioners," *Power and Energy Conference 2004, Proceedings. National*, Nov. 2004, pp. 109-115.
- [13] Hirofumi Akagi, Yoshihira kanazawa and Akira Nabae, "instantaneous reactive power compensator comprising switching power devices without energy storage components," *IEEE Transactions on Industry Applications*, Vol. 1A-20, May/June 1984, pp. 625-630.